

UC-7400 Hardware User's Manual

First Edition, March 2006

www.moxa.com/product



Moxa Systems Co., Ltd.

Tel: +886-2-8919-1711

Fax: +886-2-8919-1722

Web: www.moxa.com

MOXA Technical Support

Worldwide: support@moxa.com.tw

The Americas support@moxa.com

UC-7400 Hardware User's Manual

The Hardware described in this manual is furnished under a license agreement and may be used only in accordance with the terms of that agreement.

Copyright Notice

Copyright © 2006 Moxa Systems Co., Ltd.
All rights reserved.
Reproduction without permission is prohibited.

Trademarks

MOXA is a registered trademark of The Moxa Group.
All other trademarks or registered marks in this manual belong to their respective manufacturers.

Disclaimer

Information in this document is subject to change without notice and does not represent a commitment on the part of Moxa.

Moxa provides this document "as is," without warranty of any kind, either expressed or implied, including, but not limited to, its particular purpose. Moxa reserves the right to make improvements and/or changes to this manual, or to the products and/or the programs described in this manual, at any time.

Information provided in this manual is intended to be accurate and reliable. However, Moxa Technologies assumes no responsibility for its use, or for any infringements on the rights of third parties that may result from its use.

This product might include unintentional technical or typographical errors. Changes are periodically made to the information herein to correct such errors, and these changes are incorporated into new editions of the publication.

Table of Contents

Chapter 1	Introduction	1-1
	Overview.....	1-2
	Package Checklist.....	1-2
	Product Features	1-3
	Product Hardware Specifications	1-4
	Hardware Introduction	1-5
	Appearance and Dimensions	1-5
	Hardware Block Diagram.....	1-12
	LED Indicators	1-13
	Reset-type Buttons	1-13
	Real Time Clock.....	1-14
	Placement Options	1-14
	Wall or Cabinet	1-14
	DIN-Rail Mounting	1-15
	Hardware Connection Description.....	1-16
	Wiring Requirements	1-16
	Connecting the Power	1-16
	Grounding UC-7400.....	1-16
	Connecting to the Network.....	1-17
	Connecting to a Serial Device	1-17
	Connecting to the Console Port.....	1-18
	PCMCIA.....	1-18
	CompactFlash.....	1-18
	USB	1-18
	DI/DO.....	1-18
Appendix A	Service Information.....	A-1
	MOXA Internet Services.....	A-2
	Problem Report Form	A-3
	Product Return Procedure	A-4

Thank you for purchasing the MOXA UC-7400 RISC-based ready-to-run embedded computer. The product's features include eight RS-232/422/485 serial ports, dual 10/100 Mbps Ethernet ports, 8 digital input channels and 8 digital output channels, a PCMCIA interface for wireless LAN communication, and CompactFlash and USB ports for mass storage disk expansion. All these make the UC-7400 series ideal for your embedded applications.

This manual introduces the hardware that makes the UC-7400 series embedded computers tick. After a brief introduction of the hardware features, this manual focuses on installation and hardware configuration with device interfaces.

The following topics are covered in this chapter:

- ❑ **Overview**
 - Package Checklist
 - Product Features
 - Product Hardware Specifications
- ❑ **Hardware Introduction**
 - Appearance and Dimensions
 - Hardware Block Diagram
 - LED Indicators
 - Reset-type Buttons
 - Real Time Clock
- ❑ **Placement Options**
 - Wall or Cabinet
 - DIN-Rail Mounting
- ❑ **Hardware Connection Description**
 - Wiring Requirements
 - Connecting the Power
 - Grounding UC-7400
 - Connecting to the Network
 - Connecting to a Serial Device
 - Connecting to the Console Port
 - PCMCIA
 - CompactFlash
 - USB
 - DI/DO

Overview

The MOXA UC-7400 Series (herein after referred to as UC-7400) includes UC-7420, UC-7410, UC-7408, and UC-7402. These RISC-based ready-to-run embedded computers are ideal for embedded applications. UC-7400 series feature 8 RS-232/422/485 serial ports, dual 10/100 Mbps Ethernet ports, 8 digital input channels and 8 digital output channels, a PCMCIA interface for wireless LAN communication, a CompactFlash slot for flash disk expansion, and USB ports for adding additional memory (such as a USB Flash disk).

The UC-7400 series use an Intel XScale IXP-422 266 MHz RISC CPU. Unlike the X86 CPU, which uses a CISC design, the IXP-422's RISC design architecture and modern semiconductor technology provide UC-7400 with a powerful computing engine and communication functions, but without generating a lot of heat. The built-in 32 MB NOR Flash ROM and 128 MB SDRAM give you enough memory to run your application software directly on UC-7400. As the dual LAN ports are built right into the IXP-422 CPU, UC-7400 makes an ideal communication platform for Network Security applications. If your application requires placing UC-7400 at a site that is not located near an Ethernet LAN connection, you can connect to the network by using UC-7400's PCMCIA port to attach a wireless LAN card.

Package Checklist

All models of the UC-7400 series are shipped with the following items:

- 1 UC-7400 Series Embedded Computer
- Wall-Mounting Kit
- DIN-Rail Mounting Kit
- Quick Installation Guide
- Document & Software CD
- Cross-over Ethernet cable
- CBL-RJ45M9-150: 150 cm, 8-pin RJ45 to Male DB9 serial port cable (Except UC-7402)
- CBL-RJ45F9-150: 150 cm, 8-pin RJ45 to Female DB9 console port cable
- Universal Power Adapter
- Product Warranty Booklet

NOTE: Notify your sales representative if any of the above items is missing or damaged.

Product Features

- Intel XScale IXP-422 266 MHz Processor
- On-board 128 MB RAM, 32 MB Flash ROM
- Eight RS-232/422/485 serial ports (UC-7420/7410/7408 only)
- 8 digital input channels and 8 digital output channels (UC-7408 only)
- Dual 10/100 Mbps Ethernet
- USB 2.0 host for mass storage devices (UC-7420 only)
- PCMCIA, wireless LAN expansion (supports 802.11b/802.11g)
- CompactFlash for storage expansion (UC-7420/7408/7402 only)
- LCM display and keypad for HMI (UC-7420/7410 only)
- Ready-to-run Linux / WinCE 5.0 .NET platform
- DIN-Rail or wall mounting installation
- Robust, fanless design



UC-7420/7410



UC-7408



UC-7402

Product Hardware Specifications

	UC-7420	UC-7410	UC-7408	UC-7402
CPU	Intel Xscale IXP-422 266MHz	Intel Xscale IXP-422 266MHz	Intel Xscale IXP-422 266MHz	Intel Xscale IXP-422 266MHz
RAM	128 MB	128 MB	128 MB	128 MB
Flash	32 MB	32 MB	32 MB	32 MB
LAN	Auto-sensing 10/100 Mbps x 2 with built-in 1.5 KV magnetic isolation protection RJ45 Connector			
Serial Port	RS-232/422/485 × 8 RJ45 Connector	RS-232/422/485 × 8 RJ45 Connector	RS-232/422/485 × 8 RJ45 Connector	N/A
Serial Protection	15 KV ESD for all signals			N/A
Data Bits	5, 6, 7, 8			N/A
Stop Bits	1, 1.5, 2			N/A
Parity	none, even, odd, space, mark			N/A
Flow Control	RTC/CTS, XON/XOFF, RS-485 ADDC™			N/A
Speed	50 bps to 921.6 Kbps			N/A
Serial Console	RS-232 × 1 RJ45 Connector	RS-232 × 1 RJ45 Connector	RS-232 × 1 RJ45 Connector	RS-232 × 1 RJ45 Connector
DI/DO	N/A	DI × 8, DO × 8	N/A	N/A
USB 2.0 Hosts	2	N/A	N/A	N/A
USB 1.1 Client	1*	1*	1*	1*
PCMCIA	Cardbus x 1**	N/A	Cardbus x 1**	Cardbus x 1**
Storage Expansion	CompactFlash × 1***	N/A	CompactFlash × 1***	CompactFlash × 1***
LCM	128 × 64 dots	128 × 64 dots	N/A	N/A
Keypad	5	5	N/A	N/A
Real Time Clock	Yes	Yes	Yes	Yes
Buzzer	Yes	Yes	Yes	Yes
Rest Button	HW Reset × 1 Reset to Default × 1	HW Reset × 1 Reset to Default × 1	HW Reset × 1 Reset to Default × 1	HW Reset × 1 Reset to Default × 1
Power Input	12 to 48 VDC	12 to 48 VDC	12 to 48 VDC	12 to 48 VDC
Power Consumption	12W	10W	8W	7W
Dimension (W x D x H)	197 × 125 × 44 mm	197 × 125 × 44 mm	197 × 125 × 44 mm	197 × 125 × 44 mm
Weights	875 g	810 g	870 g	830 g
Operating temperature	-10 to 60°C, (14 to 140°F), 5 to 95% RH			
Storage temperature	-20 to 80°C, (-4 to 176°F), 5 to 95% RH			
Regulatory Approvals	EMC: CE Class A, FCC Class A Safety: UL, cUL, TÜV			
Warranty	5 years	5 years	5 years	5 years

* USB Client function is reserved for future enhancement

** PCMCIA is designed for 802.11b/g wireless LAN card expansion

*** CompactFlash is designed for Flash memory card or Microdrive

Hardware Introduction

Appearance and Dimensions

Appearance

UC-7420 Rear View

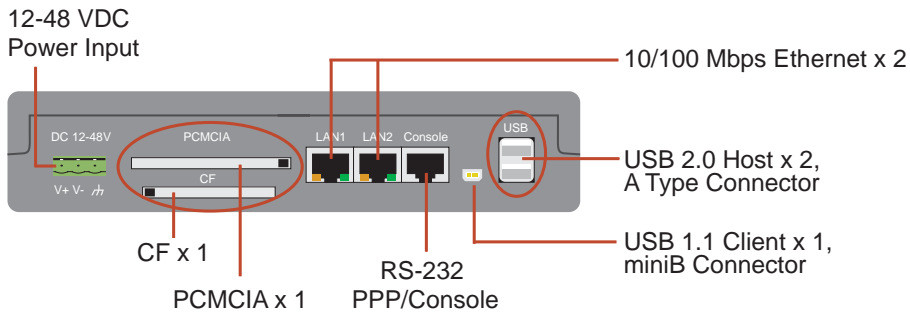

UC-7420 Top View

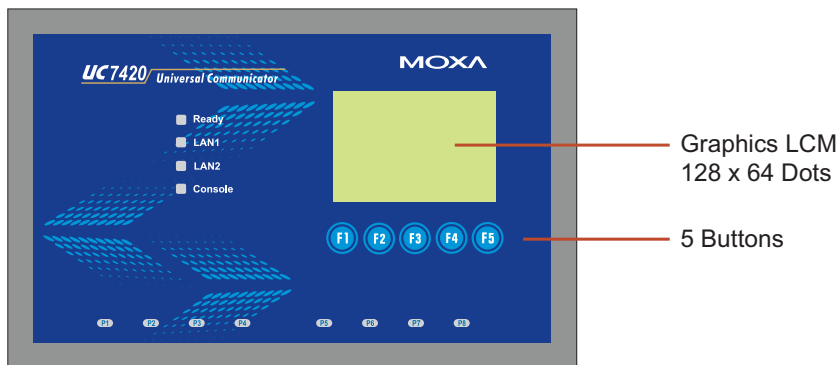

UC-7420 Front View

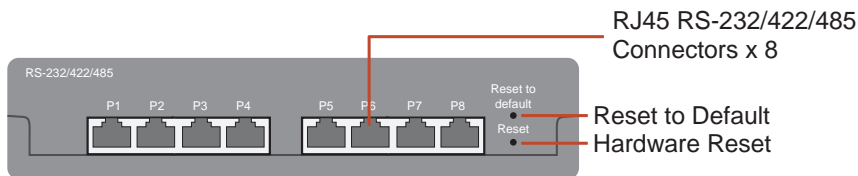

UC-7410 Rear View

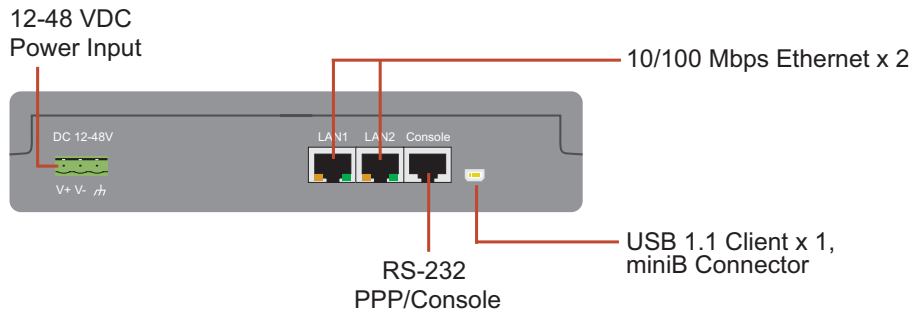

UC-7410 Top View

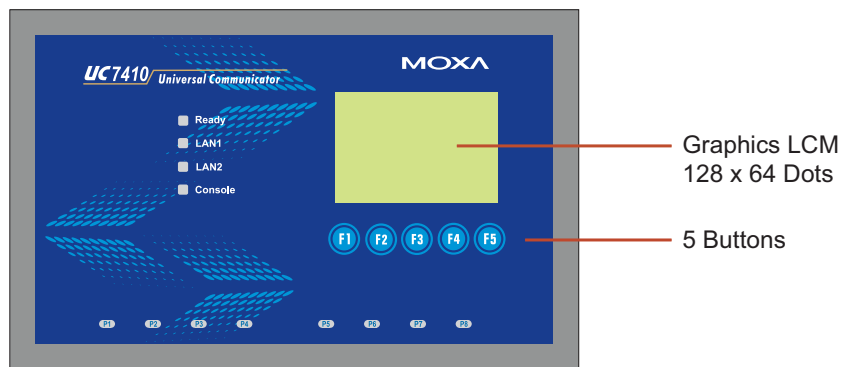

UC-7410 Front View

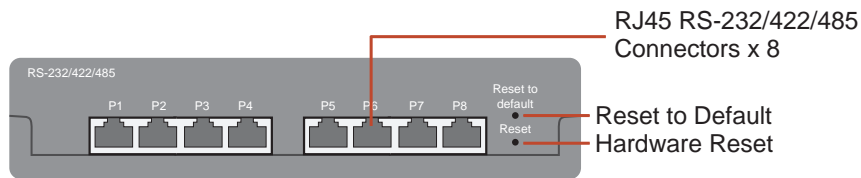

UC-7408 Rear View

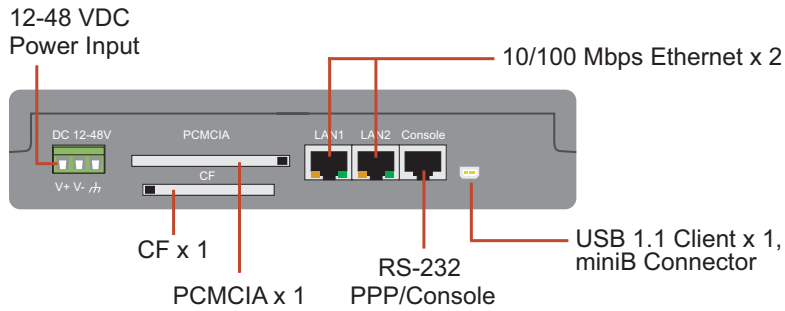

UC-7408 Top View

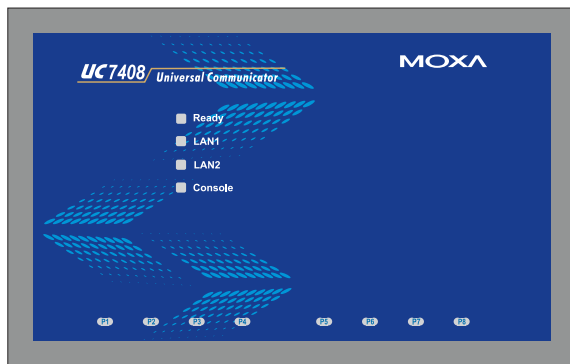

UC-7408 Front View

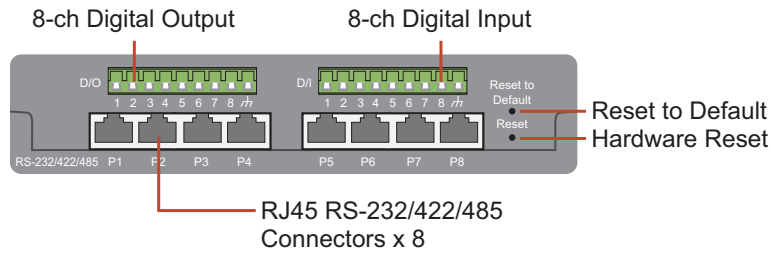

UC-7402 Rear View

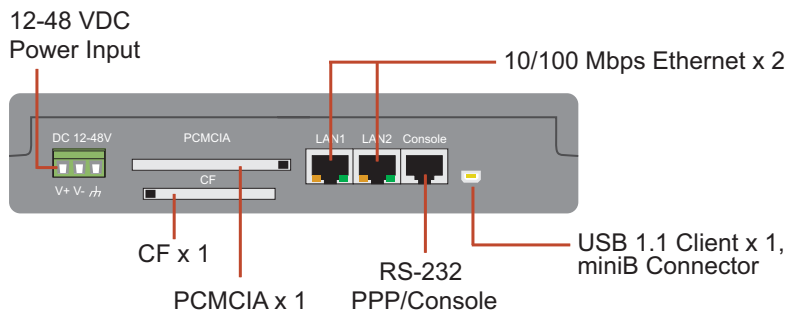

UC-7402 Top View

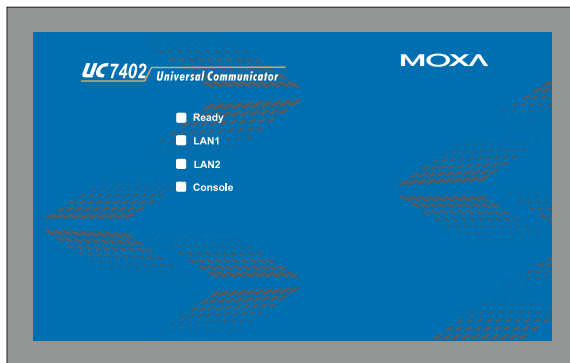

UC-7402 Front View



Dimensions

UC-7420/7410

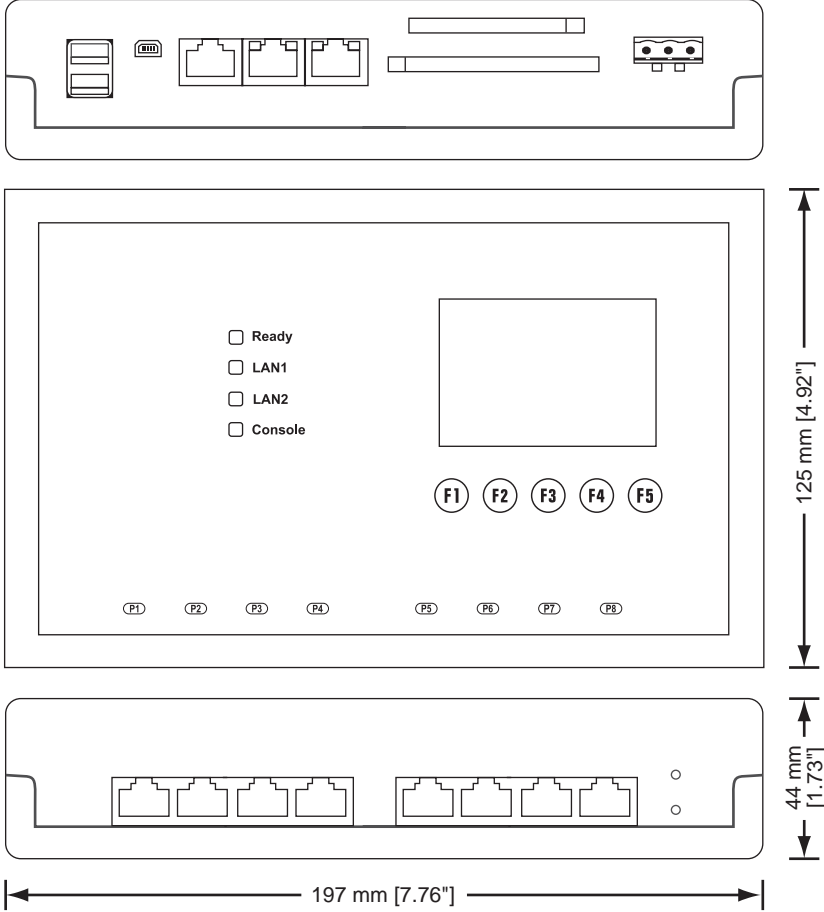

UC-7408

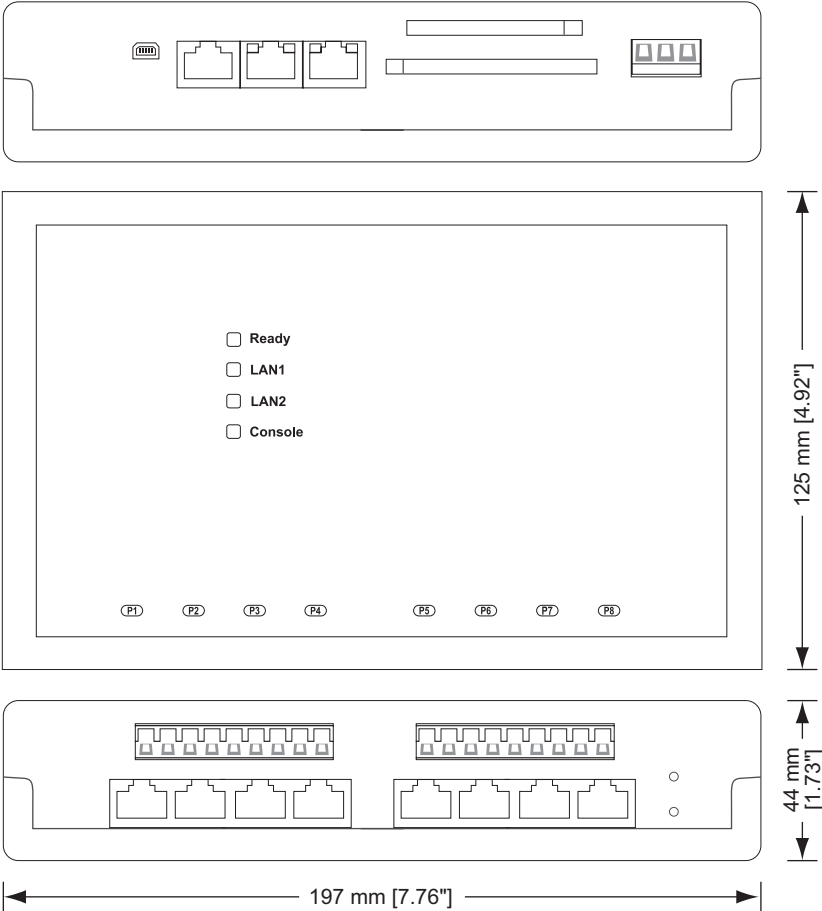

UC-7402

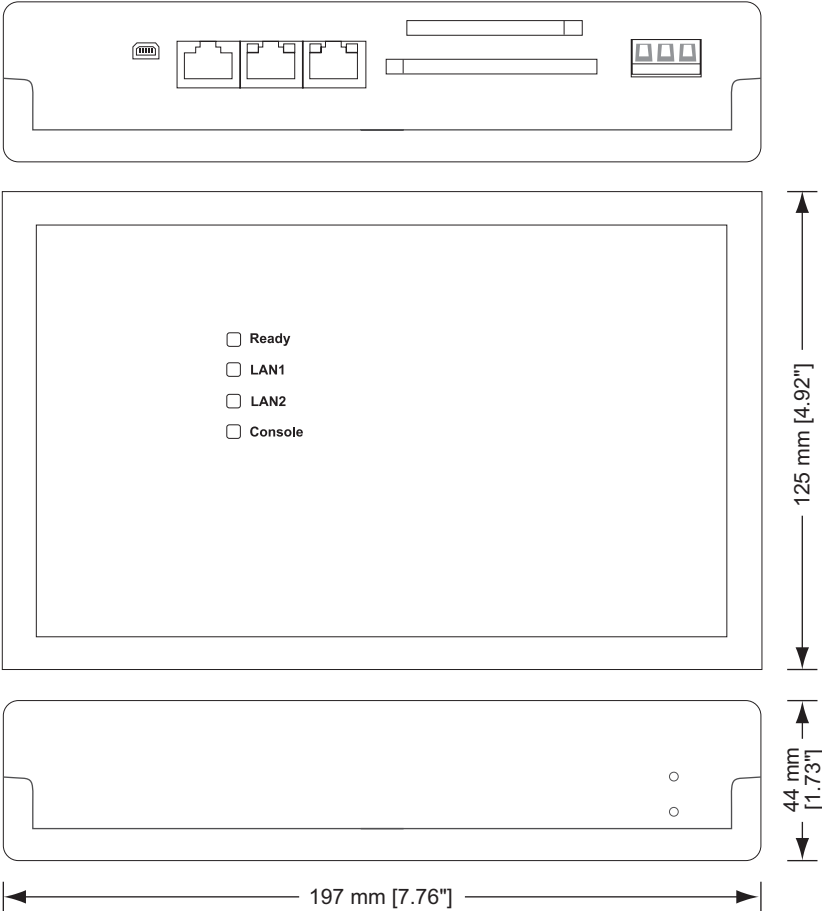

Hardware Block Diagram

The following block diagram shows the layout of UC-7420 internal components.

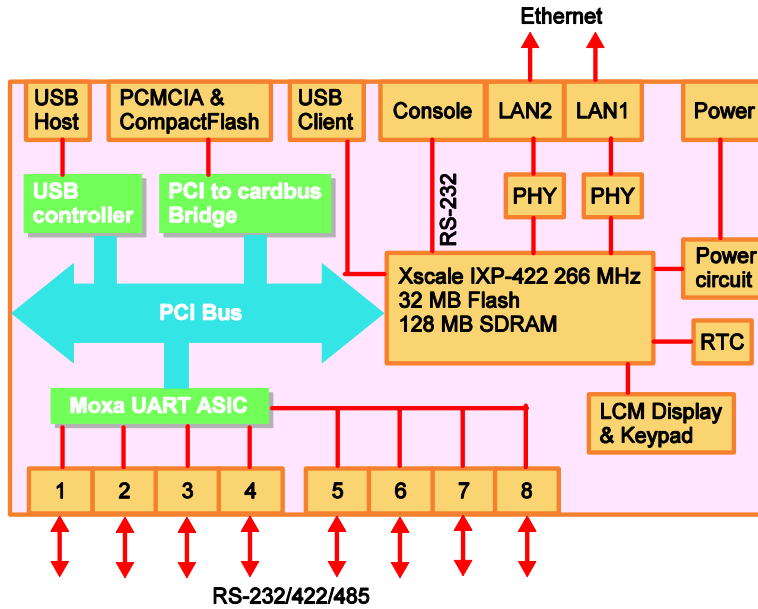

The following block diagram shows the layout of UC-7410 internal components.

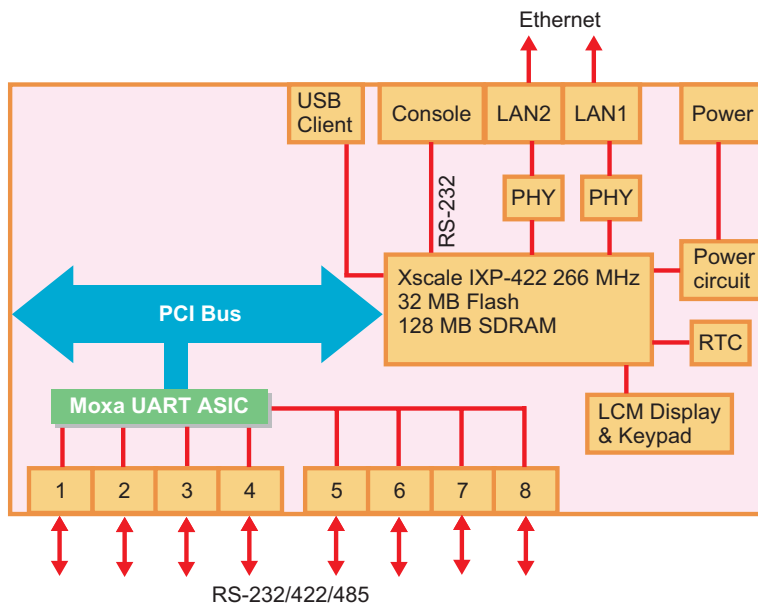

The following block diagram shows the layout of UC-7408's internal components.

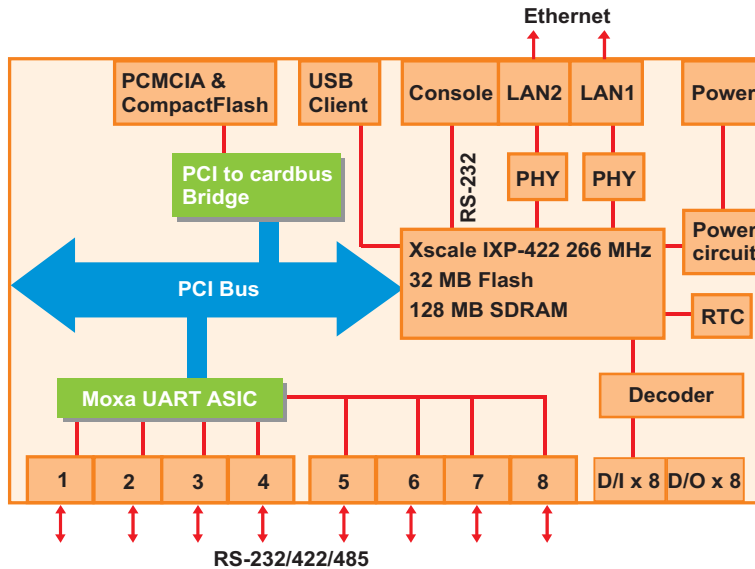

The following block diagram shows the layout of UC-7402's internal components.

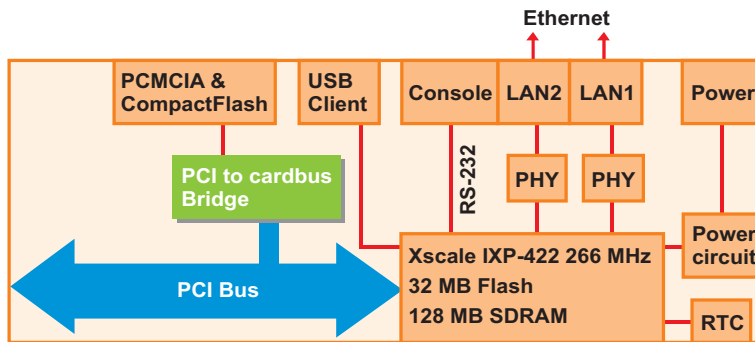

LED Indicators

UC-7420/7410 /7408 have 12 LED indicators on the top panel. UC-7402 has only 4 LED indicators (no serial port indicator) on the top panel. Refer to the following table for information about each LED.

LED Name	Color	Meaning
Ready	Green	Power is ON, and system is ready (after booting up)
LAN1, LAN2	Yellow	10 Mbps Ethernet connection
	Green	100 Mbps Ethernet connection
Console	Yellow	Console port is receiving RX data from the serial device.
	Green	Console port is transmitting TX data to the serial device.
P1, P2, P3, P4, P5, P6, P7, P8	Yellow	Serial port is receiving RX data from the serial device.
	Green	Serial port is transmitting TX data to the serial device.

Reset-type Buttons

UC-7400 has two reset-type buttons. The button labeled Reset has the same effect as switching off the power and then switching the power back on. The button labeled Reset to default returns UC-7400 to the factory default parameter configuration.

Reset Button

Pressing the **Reset** button initiates a hardware reboot. The button plays the same role as a desktop PC's reset button.

In normal use, you should NOT use the **Reset** Button. You should only use this function if the software is not working properly. To reset an embedded linux system, always use the software reboot command `/>reboot` to protect the integrity of data being transmitted or processed.

Reset to default Button

Press the **Reset to default** button continuously for at least 5 seconds to load the **factory default configuration**. After the factory default configuration has been loaded, the system will reboot automatically. The **Ready** LED will blink on and off for the first 5 seconds, and then maintain a steady glow once the system has rebooted.

We recommend that you only use this function if the software is not working properly and you want to load factory default settings. To reset an embedded linux system, always use the software reboot command `/>reboot` to protect the integrity of data being transmitted or processed. The **Reset to default** button is not designed to hard reboot UC-7400.



ATTENTION

Reset to default preserves user's data

The **Reset to default** button will NOT format the user directory and erase the user's data. Pressing the Reset to default button will only load the configuration file. All files in the `/etc` directory will revert to their factory defaults, but other User Data will still exist in the Flash ROM.

"Reset to Default" is not supported by UC-7420/7410 hardware versions V1.0

The **Reset to default** button is not supported by UC-7420/7410 hardware version V1.0. You can identify the hardware version from UC-7420/7410's lower label. You need to contact MOXA to determine the product's hardware version. When contacting our customer support team, you will need to provide the product's Serial Number (S/N) that is found on UC-7420/7410's lower label.

Real Time Clock

UC-7400's real time clock is powered by a lithium battery. We strongly recommend that you do not replace the lithium battery without help from a qualified MOXA support engineer. If you need to change the battery, contact MOXA RMA service team.



WARNING

There is a risk of explosion if the battery is replaced by an incorrect type.

Placement Options

Wall or Cabinet

The two metal brackets that come standard with UC-7400 are used to attach UC-7400 to a wall, or the inside of a cabinet. First, use two screws per bracket to attach the brackets to the bottom of UC-7400 (Fig. A). Next, use two screws per bracket to attach the UC-7400 to a wall or cabinet (Fig. B).

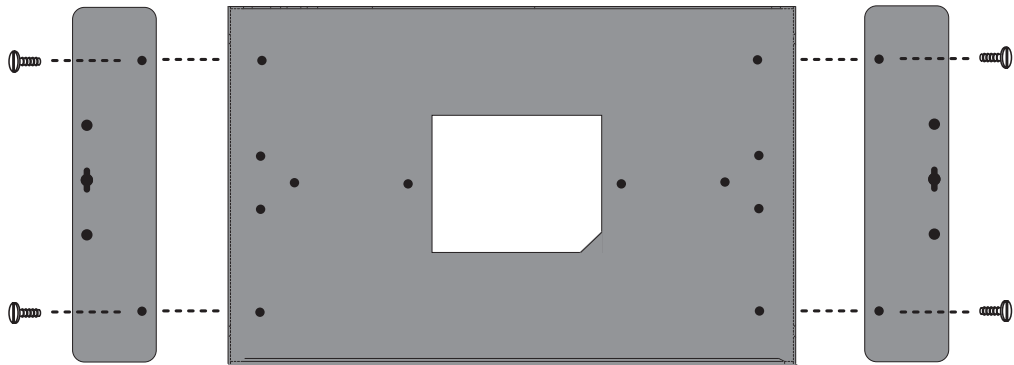

Figure A: UC-7420/7410 Universal Communicator—Wall Mounting Brackets (bottom view)

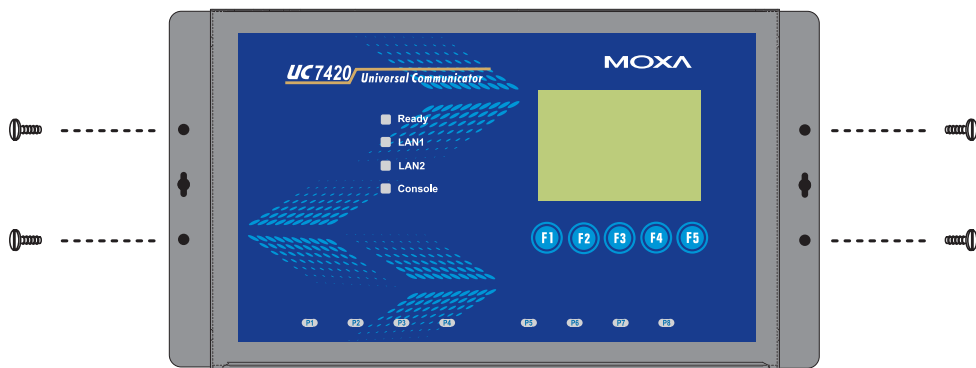

Figure B: UC-7420/7410 Universal Communicator—Wall Mounting Brackets (top view)

DIN-Rail Mounting

The aluminum DIN-Rail attachment plate is included with the package. If you need to reattach the DIN-Rail attachment plate to UC-7400, make sure the stiff metal spring is situated towards the top, as shown by the following figures.

STEP1: Insert the top of the DIN-Rail into the slot just below the stiff metal spring.

STEP2: The DIN-Rail attachment unit will snap into place as shown.

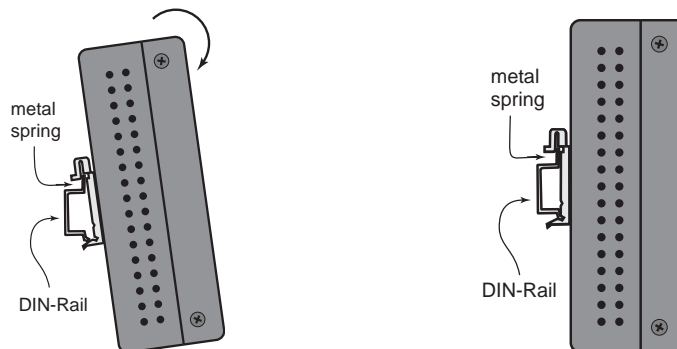

To remove UC-7400 from the DIN-Rail, simply reverse Steps 1 and 2.

Hardware Connection Description

This section describes how to connect UC-7420/7410 to serial devices for first time testing purposes. We cover **Wiring Requirements**, **Connecting the Power**, **Grounding UC-7400**, **Connecting to the Network**, **Connecting to a Serial Device**, **Connecting to the Console Port**, **PCMCIA**, **CompactFlash**, **USB**, and **DI/DO**.

Wiring Requirements



ATTENTION

Safety First!

Be sure to disconnect the power cord before installing and/or wiring your UC-7400.

Wiring Caution!

Calculate the maximum possible current in each power wire and common wire. Observe all electrical codes dictating the maximum current allowable for each wire size.

If the current goes above the maximum ratings, the wiring could overheat, causing serious damage to your equipment.

Temperature Caution!

Be careful when handling UC-7400. When plugged in, UC-7400's internal components generate heat, and consequently the outer casing may feel hot to the touch.

You should also observe the following common wiring rules:

- Use separate paths to route wiring for power and devices. If power wiring and device wiring paths must cross, make sure the wires are perpendicular at the intersection point.
NOTE: Do not run signal or communication wiring and power wiring in the same wire conduit. To avoid interference, wires with different signal characteristics should be routed separately.
- You can use the type of signal transmitted through a wire to determine which wires should be kept separate. The rule of thumb is that wiring that shares similar electrical characteristics can be bundled together.
- Keep input wiring and output wiring separate.
- Where necessary, it is strongly advised that you label wiring to all devices in the system.

Connecting the Power

Connect the 12 to 48 VDC power line with UC-7400's terminal block. If the power is properly supplied, the **Ready** LED will illuminate with a solid green color after 30 to 60 seconds have passed.

Grounding UC-7400

Grounding and wire routing helps limit the effects of noise due to electromagnetic interference (EMI). Run the ground connection from the ground screw to the grounding surface prior to connecting devices.



ATTENTION

This product is intended to be mounted to a well-grounded mounting surface, such as a metal panel.

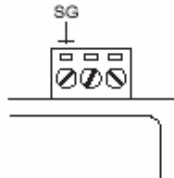

SG: The *Shielded Ground* (sometimes called *Protected Ground*) contact is the left most contact of the 3-pin power terminal block connector when viewed from the angle shown here. Connect the SG wire to an appropriate grounded metal surface.

Connecting to the Network

Connect one end of the Ethernet cable to one of UC-7400's 10/100M Ethernet ports (8-pin RJ45) and the other end of the cable to the Ethernet network. If the cable is properly connected, UC-7420/7410 will indicate a valid connection to the Ethernet in the following ways:

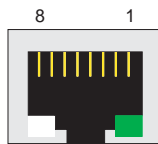

The lower right corner LED indicator maintains a solid green color when the cable is properly connected to a 100 Mbps Ethernet network. The LED will flash on and off when Ethernet packets are being transmitted or received.

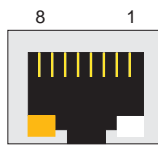

The lower left corner LED indicator maintains a solid orange color when the cable is properly connected to a 10 Mbps Ethernet network. The LED will flash on and off when Ethernet packets are being transmitted or received.

Pin	Signal
1	ETx+
2	ETx-
3	ERx+
4	---
5	---
6	ERx-
7	---
8	---

Connecting to a Serial Device

Use properly wired serial cables to connect UC-7420/7410/7408 to serial devices. UC-7420/7410/7408's serial ports (P1 to P8) use 8-pin RJ45 connectors. The ports can be configured by software for RS-232, RS-422, or 2-wire RS-485. The precise pin assignments are shown in the following table:

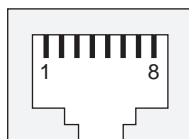

Pin	RS-232	RS-422	RS-485
1	DSR	---	---
2	RTS	TXD+	---
3	GND	GND	GND
4	TXD	TXD-	---
5	RXD	RXD+	Data+
6	DCD	RXD-	Data-
7	CTS	---	---
8	DTR	---	---

Connecting to the Console Port

UC-7400's console port is an 8-pin RJ45 RS-232 port. The port can be used to connect to the console utility from a remote console via a V90 or GPRS modem with PPP protocol. The pin definition is the same as for the serial ports (P1 to P8). For normal data acquisition applications, you should connect to UC-7400's serial ports (P1 to P8) via a V90 or GPRS modem. If you would like to use the console port for normal data acquisition applications, you can set the Console port to startup via PPP protocol.

PCMCIA

The PCMCIA slot supports the CardBus (Card-32) Card standard and 16-bit (PCMCIA 2.1/JEIDA 4.2) Card standard. It supports +3.3V, +5V, and +12V at a working voltage of 120 mA. Wireless LAN card expansion is optional. The wireless LAN card provided by MOXA lets you connect UC-7400 to a wireless LAN, with both 802.1b and 802.11g interfaces supported. If you need device drivers for other kinds of PCMCIA cards, contact MOXA for information on how to initiate a cooperative development project.

CompactFlash

UC-7420/7408/7402 provides one CompactFlash slot that supports CompactFlash type I/II card expansion. Currently, MOXA provides a CompactFlash disk for plug & play mass storage expansion. You may also use flash disks available from most computer supply outlets. The CompactFlash card is automatically mounted as a system partition on insertion.

If you need device drivers for other kinds of mass storage cards, contact MOXA for information on how to initiate a cooperative development project.

USB

UC-7420 provides two USB 2.0 Hosts and one USB 1.1 Client, The USB Host now supports the mass storage to expansion function.

DI/DO

UC-7408 support 8-ch digital input and 8-ch digital output. The eight digital input channels and eight digital output channels use separate terminal blocks.

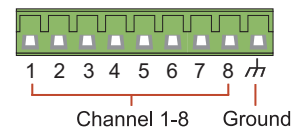

A

Service Information

This appendix shows you how to contact MOXA for information about this and other products, and how to report problems.

The following topics are covered in this appendix:

- MOXA Internet Services**
- Problem Report Form**
- Product Return Procedure**

MOXA Internet Services

Customer satisfaction is our number one concern, and to ensure that customers receive the full benefit of our products, Moxa Internet Services has been set up to provide technical support, driver updates, product information, and user's manual updates.

The following services are provided

E-mail for technical support.....support@moxa.com.tw

World Wide Web (WWW) Site for product information:

.....<http://www.moxa.com>

Product Return Procedure

For product repair, exchange, or refund, the customer must:

- ◆ Provide evidence of original purchase.
- ◆ Obtain a Product Return Agreement (PRA) from the sales representative or dealer.
- ◆ Fill out the Problem Report Form (PRF). Include as much detail as possible for a shorter product repair time.
- ◆ Carefully pack the product in an anti-static package, and send it, pre-paid, to the dealer. The PRA should be visible on the outside of the package, and include a description of the problem, along with the return address and telephone number of a technical contact.