



### Description

The GM76C88AL is a 65,536 bit static random access memory organized as 8,192 words by 8 bits using CMOS technology and operated from a single 5V supply. Advanced circuit techniques provide low power feature with a maximum operating current of 40mA and standby current of max 100µA. Its very low standby power requirement makes it ideal for applications requiring nonvolatile storage with back-up batteries. The asynchronous and static nature of the memory requires no external clock or refreshing circuits.

### Features

- Fast Access Time : 120/150ns
- Low Power Operation
  - Standby : 2µA (Typ)
  - Operation : 25mA (Typ)
- Completely Static RAM : No Clock or Timing Strobe Required
- Non-Volatile Storage with Back-up Batteries
- 3-State Output with Wired-OR Capability
- Directly TTL Compatible : All Inputs and Outputs
- Single Power Supply (5V ± 10%)
- Standard 28 DIP, SOP and S-DIP

### Pin Description

Pin	Function
A0-A12	Address Inputs
$\overline{WE}$	Write Enable Input
$\overline{CS1}$ , CS2	Chip Select
$\overline{OE}$	Output Enable
I/O0-I/O7	Data Input/Output
Vcc	Power Supply (+5V)
Vss	Ground
NC	No Connection

### Pin Configuration

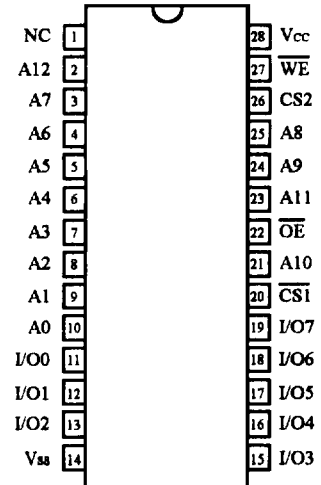

(Top View)

### Block Diagram

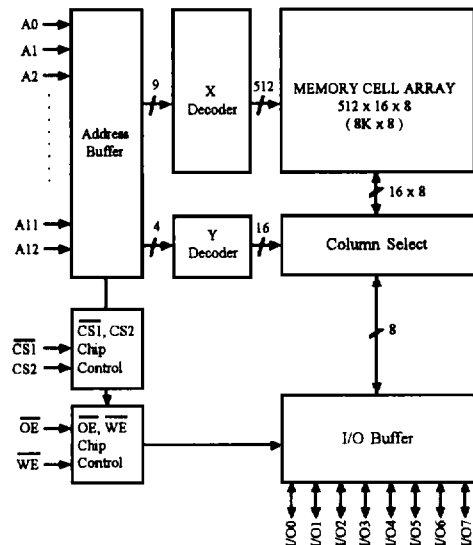

## Absolute Maximum Ratings

Symbol	Parameter	Rating	Unit
T <sub>A</sub>	Ambient Temperature under Bias	0 ~ 70	°C
T <sub>STG</sub>	Storage Temperature	-65 ~ 150	°C
T <sub>SOL</sub>	Soldering Temperature and Time	260, 10 (at lead)	°C, S
V <sub>CC</sub>	Supply Voltage	-0.5 ~ 7.0	V
V <sub>IN</sub>	Input Voltage	-0.5 ~ 7.0	V
P <sub>D</sub>	Power Dissipation	1.0	W

Recommended Operating Conditions (T<sub>A</sub> = 0 ~ 70°C)

Symbol	Parameter	Min	Typ	Max	Unit
V <sub>CC</sub>	Supply Voltage	4.5	5.0	5.5	V
V <sub>IH</sub>	Input High Voltage	2.2	-	V <sub>CC</sub> + 0.5	V
V <sub>IL</sub>	Input Low Voltage	-0.5	-	0.8	V

## Truth Table

$\overline{CS1}$	CS2	$\overline{OE}$	$\overline{WE}$	A0 to A12	DATA I/O	MODE
H	X	X	X	-	Hi-Z	Standby
X	L	X	X	-	Hi-Z	
L	H	X	L	Stable	Input Data	Write
L	H	L	H	Stable	Output Data	Read
L	H	H	H	Stable	Hi-Z	Output Disable

\*Note: X means don't care.

DC Electrical Characteristics (V<sub>CC</sub> = 5V ± 10%, T<sub>A</sub> = 0 ~ 70°C)

Symbol	Parameter	Conditions	Min	*Typ	Max	Unit	
V <sub>OH</sub>	Output High Voltage	I <sub>OH</sub> = -1.0mA	2.4	V <sub>CC</sub> -0.1	-	V	
V <sub>OL</sub>	Output Low Voltage	I <sub>OL</sub> = 4.0mA	-	0.2	0.4	V	
I <sub>I(L)</sub>	Input Leakage Current	V <sub>I</sub> = 0 to V <sub>CC</sub>	-	-	1	μA	
I <sub>O(L)</sub>	Output Leakage Current	$\overline{CS1} = V_{IH}$ or CS2 = V <sub>IL</sub> or $\overline{WE} = V_{IL}$ or $\overline{OE} = V_{IH}$ , V <sub>IO</sub> = 0 to V <sub>CC</sub>	-	-	1	μA	
I <sub>CC1</sub>	Operating Supply Current	V <sub>I</sub> = V <sub>IL</sub> , V <sub>IH</sub> I <sub>IO</sub> = 0mA	t <sub>RC</sub> = 1μs	-	6	10	mA
I <sub>CC2</sub>			t <sub>PC</sub> = Min	-	25	40	
		V <sub>I</sub> = 0.2V/V <sub>CC</sub> -0.2V I <sub>IO</sub> = 0mA	t <sub>RC</sub> = 1μs	-	3	5	mA
t <sub>PC</sub> = Min			-	20	35		
I <sub>CCS1</sub>	Standby Power Supply Current	$\overline{CS1} = V_{IH}$ or CS2 = V <sub>IL</sub>	-	1.5	3	mA	
I <sub>CCS2</sub>		$\overline{CS1} = CS2 \geq V_{CC}-0.2V$ or CS2 ≤ 0.2V	-	2	100	μA	

\*TYP. Values are measured at 25°C, V<sub>CC</sub> = 5V

AC Electrical Characteristics ( $V_{CC} = 5V \pm 10\%$ ,  $T_A = 0 \sim 70^\circ\text{C}$ )

## Read Cycle

Symbol	Parameter	Conditions	GM76C88AL-12		GM76C88AL-15		Unit
			Min	Max	Min	Max	
$t_{RC}$	Read Cycle Time	*1	120	-	150	-	ns
$t_{AA}$	Address Access Time		-	120	-	150	ns
$t_{ACS1}$	Chip Select 1 Access Time		-	120	-	150	ns
$t_{ACS2}$	Chip Select 2 Access Time		-	120	-	150	ns
$t_{OE}$	Output Enable Access Time		-	60	-	70	ns
$t_{OH}$	Output Hold Time		30	-	30	-	ns
$t_{CLZ1}$	Chip Select 1 Output Setup Time	*2	10	-	10	-	ns
$t_{CHZ1}$	Chip Select 1 Output Floating		-	60	-	70	ns
$t_{CLZ2}$	Chip Select 2 Output Setup Time		10	-	10	-	ns
$t_{CHZ2}$	Chip Select 2 Output Floating		-	60	-	70	ns
$t_{OLZ}$	Output Enable Output Setup Time		5	-	5	-	ns
$t_{OHZ}$	Output Enable Output Floating		-	55	-	60	ns

## Write Cycle

Symbol	Parameter	Conditions	GM76C88AL-12		GM76C88AL-15		Unit
			Min	Max	Min	Max	
$t_{WC}$	Write Cycle Time	*1	120	-	150	-	ns
$t_{CW1}$	Chip select Time 1		100	-	120	-	ns
$t_{CW2}$	Chip Select Time 2		100	-	120	-	ns
$t_{AW}$	Address Enable Time		100	-	120	-	ns
$t_{AS}$	Address Setup Time		0	-	0	-	ns
$t_{WP}$	Write Pulse Width		85	-	100	-	ns
$t_{WR}$	Address Hold Time		0	-	0	-	ns
$t_{DW}$	Input Data Setup Time		50	-	60	-	ns
$t_{DH}$	Input Data Hold Time		0	-	0	-	ns
$t_{WHZ}$	R/W Output Floating	*2	-	60	-	70	ns
$t_{OW}$	R/W Output Setup Time		10	-	10	-	ns

**\*1 Test Conditions.**

1. Input pulse level : 0.8V to 2.2V
2.  $t_r = t_f = 5ns$
3. Input/output timing reference level : 1.5V
4. Output load : 1TTL + 100pF

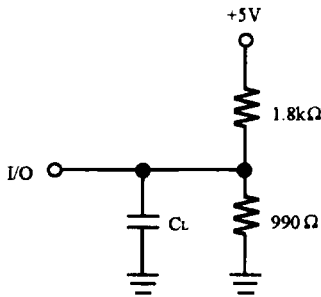

$C_L = 100pF$  (Includes Jig Capacitance)

**\*2 Test Conditions.**

1. Input pulse level : 0.8V to 2.2V
2.  $t_r = t_f = 10ns$
3. Input timing reference level : 1.5V
4. Output timing reference levels :  $\pm 200mV$  (the level displace from stable output voltage level)
5. Output load : 1TTL + 5pF

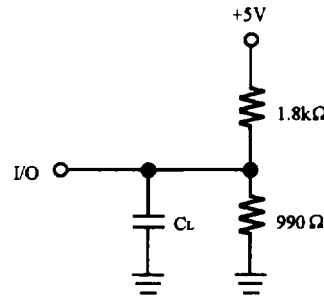

$C_L = 5pF$  (Includes Jig Capacitance)

**Capacitance ( $f = 1MHz, T_A = 25^\circ C$ )**

Symbol	Parameter	Test Conditions	Min	Max	Unit
$C_{IN}$	Input Capacitance	$V_I = 0V$	-	6	pF
$C_{OUT}$	Output Capacitance	$V_O = 0V$	-	8	pF

## Timing Waveforms

## Read Cycle

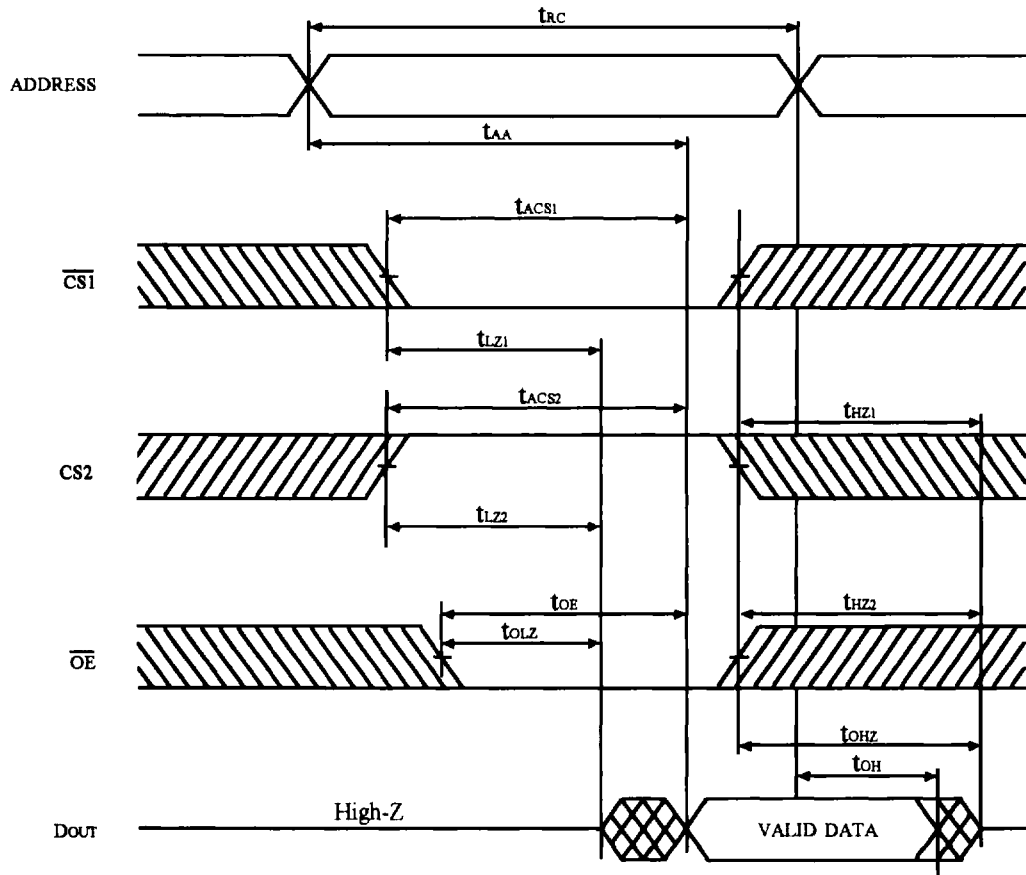

Note : 1)  $\overline{WE}$  is High for Read Cycle

Write Cycle (1) ( $\overline{OE}$  Controlled)

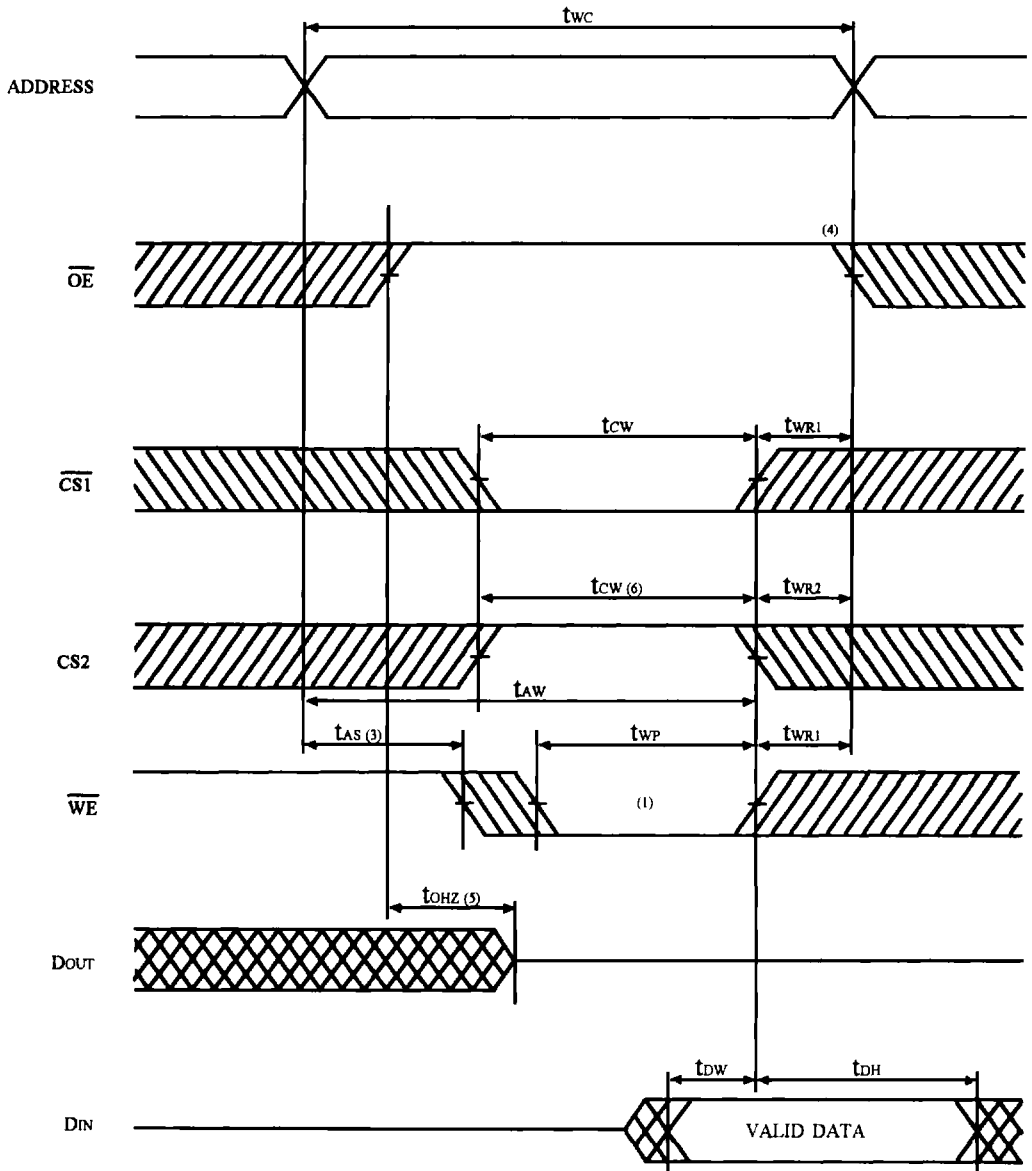

Write Cycle (2) ( $\overline{OE}$  Low Fix)

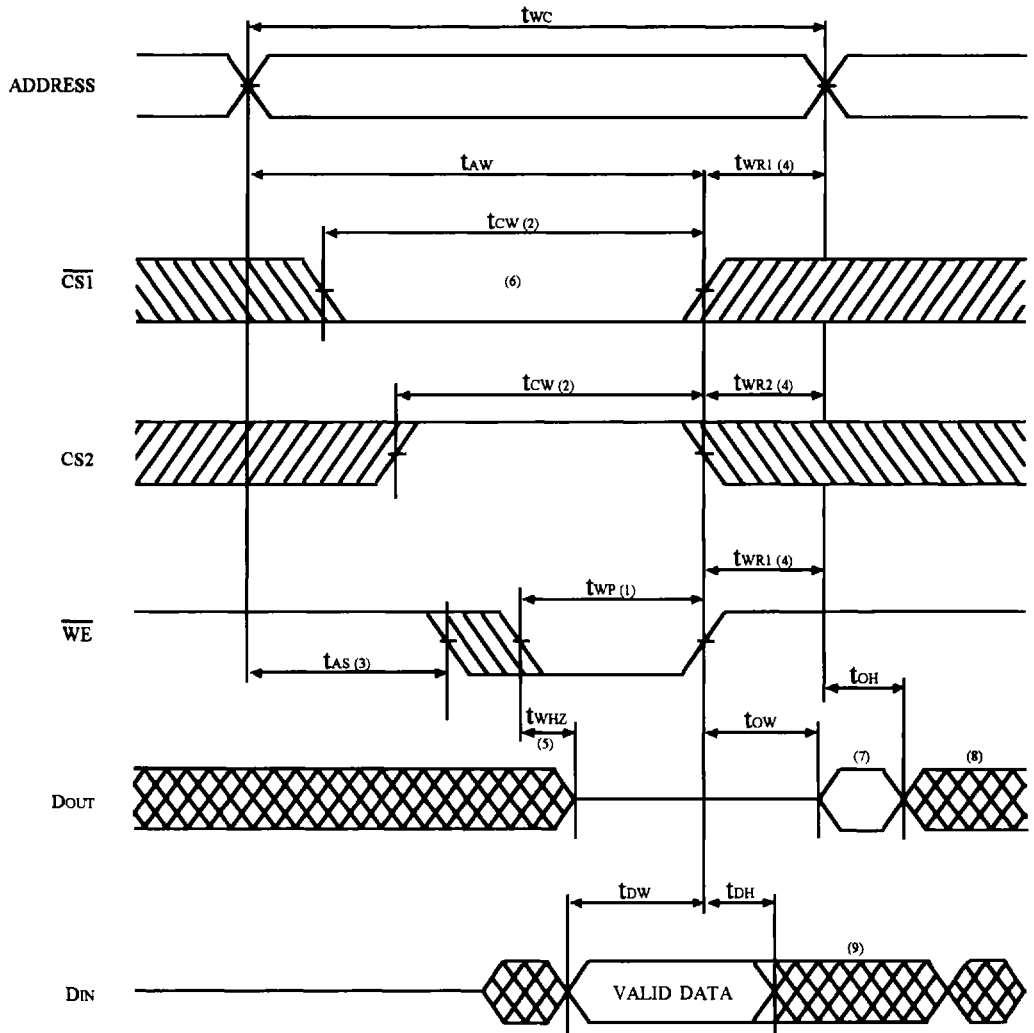

## Notes:

1. A write occurs during the overlap of a low  $\overline{CS1}$ , a high CS2 and a low  $\overline{WE}$ . A write begins at the latest transition among  $\overline{CS1}$  going low, CS2 going high and  $\overline{WE}$  going low. A write ends at the earliest transition among  $\overline{CS1}$  going high, CS2 going low and  $\overline{WE}$  going high,  $t_{wp}$  is measured from the beginning of write to the end of write.
2.  $t_{cw}$  is measured from the later of  $\overline{CS1}$  going low or CS2 going high to the end of write.
3.  $t_{as}$  is measured from the address valid to the beginning of write.
4.  $t_{wr}$  is measured from the end of write to the address change.  $t_{wr1}$  applies in case a write ends at  $\overline{CS1}$  or  $\overline{WE}$  going high.  $t_{wr2}$  applies in case a write ends at CS2 going low.
5. During this period, I/O pins are in the output state, therefore the input signals of opposite phase to the outputs must not be applied.
6. If  $\overline{CS1}$  goes low simultaneously with  $\overline{WE}$  going low or after  $\overline{WE}$  going low, the outputs remain in high impedance state.
7.  $D_{out}$  is the same phase of the latest written data in this write cycle.
8.  $D_{out}$  is the read data of next address.
9. If  $\overline{CS1}$  is low and CS2 is high during this period, I/O pins are in the output state. Therefore, the input signals of opposite phase to the outputs must not be applied to them.



Data Retention Characteristics ( $T_A = 0 \sim 70^\circ\text{C}$ )

Symbol	Parameter		Test Conditions	Min	Typ	Max	Unit
$V_{CCR}$	Data Retention Supply Voltage	$V_{CCR1}$	$\overline{CS1} \geq V_{CC}-0.2\text{V}$ , $CS2 \geq V_{CC}-0.2\text{V}$ or $CS2 \leq 0.2\text{V}$	2.0	-	5.5	V
		$V_{CCR2}$	$CS2 \leq 0.2\text{V}$	2.0	-	-	V
$I_{CCR}$	Data Retention Current	$I_{CCR1}$	$V_{CC} = 3.0\text{V}$ , $\overline{CS1} \geq V_{CC}-0.2\text{V}$ , $CS2 \geq V_{CC}-0.2\text{V}$ or $CS2 \leq 0.2\text{V}$	-	1	50*	$\mu\text{A}$
		$I_{CCR2}$	$V_{CC} = 3.0\text{V}$ , $CS2 \leq 0.2\text{V}$	-	1	50*	$\mu\text{A}$
$t_{CDR}$	Chip Select to Data Retention Time	$t_{CDR}$	See Retention Waveform	0	-	-	ns
$t_r$	Operation Recovery Time	$t_r$		$t_{rc}^{**}$	-	-	ns

\*  $V_{IL}$  min = -3V,  $1\mu\text{A}$  max at  $T_A = 0 \sim 40^\circ\text{C}$

\*\*  $t_{rc}$  = Read Cycle Time

• Low  $V_{CC}$  Data Retention Mode: (1)  $\overline{CS1}$  Controlled

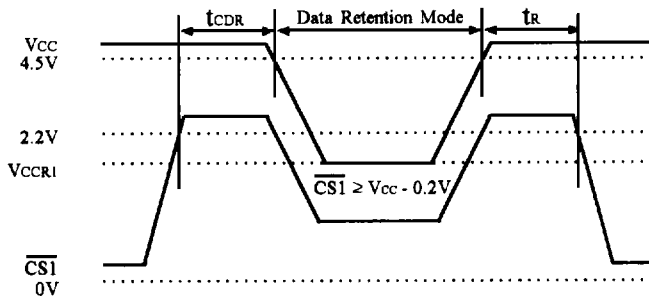

• Low  $V_{CC}$  Data Retention Mode: (2)  $CS2$  Controlled

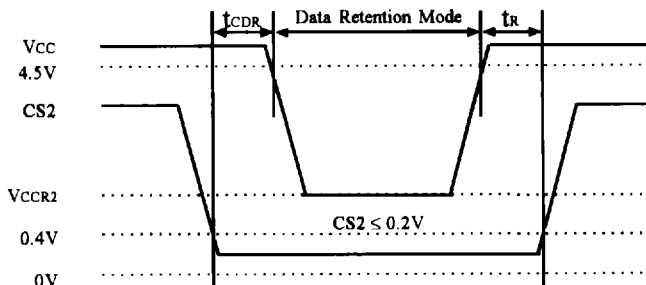

Notes: In Data Retention Mode,  $CS2$  controls the Address,  $\overline{WE}$ ,  $\overline{CS1}$ ,  $\overline{OE}$  and  $D_{in}$  buffer. If  $CS2$  controls data retention mode,  $V_{IN}$  for these inputs can be in the high impedance state. If  $\overline{CS1}$  controls the data retention mode,  $CS2$  must satisfy either  $CS2 \geq V_{CC} - 0.2\text{V}$  or  $CS2 \leq 0.2\text{V}$ . The other input levels (Address,  $\overline{WE}$ ,  $\overline{OE}$ , I/O) can be in the high impedance state.

Package Dimensions

Unit: Inches (mm)

28 DIP

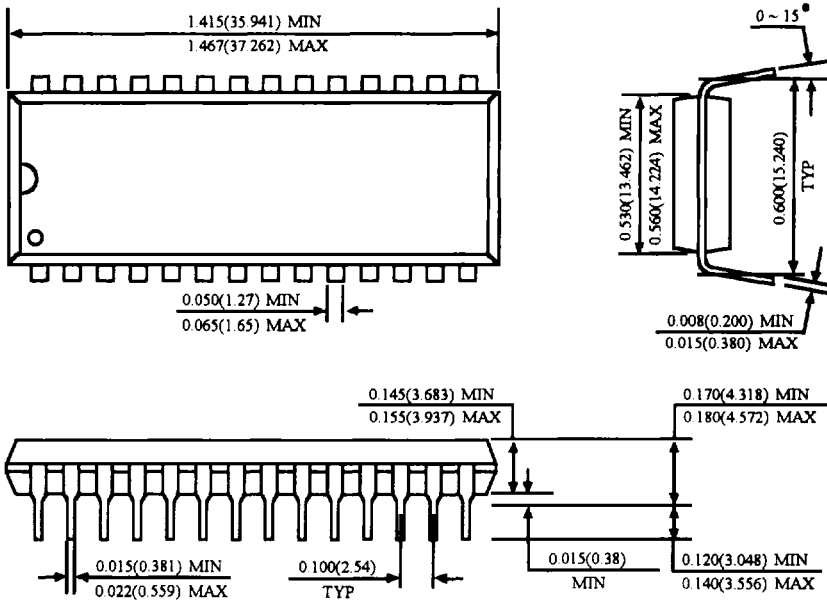

28 SOP

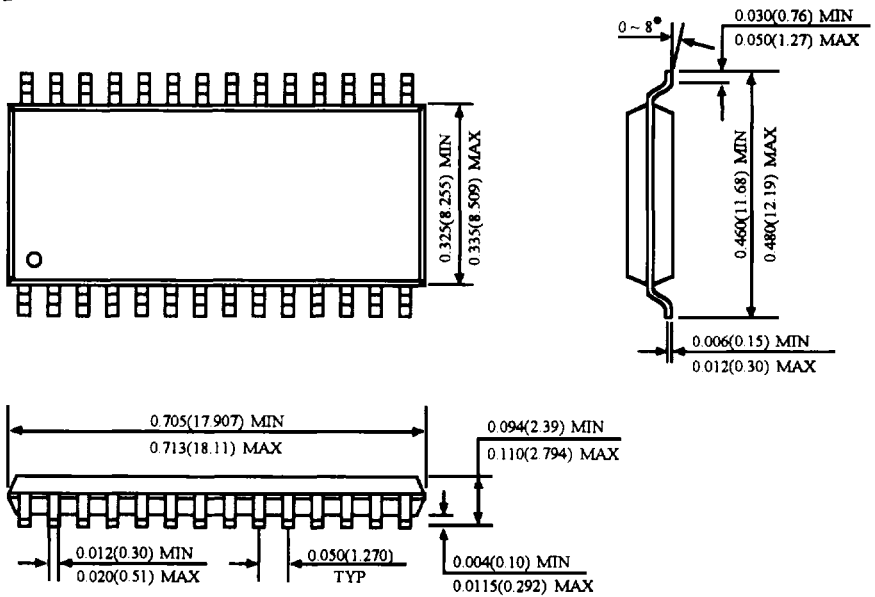

Unit: Inches (mm)

28 SKINNY DIP

